

Tools Management System for Automotive Garage



Complete Set Tools

Mac Tools 123-Piece Mechanics Tool Set

- **Description:** This extensive tool set includes a variety of sockets, wrenches, and screwdrivers, designed to meet the needs of any automotive technician.
- **Features:**
 - Chrome vanadium steel construction for durability
 - Full polish chrome finish for easy cleaning
 - Includes both metric and SAE sizes
- **Benefits:** A comprehensive tool set that allows technicians to tackle a wide range of automotive repairs and maintenance tasks efficiently.

Mac Tools 3/8" Drive Socket Set

- **Description:** A specialized socket set featuring a range of sizes for various applications.
- **Features:**
 - 72-tooth ratchet for improved access in tight spaces
 - Deep and shallow sockets included
- **Benefits:** Ideal for both professional and DIY mechanics, providing versatility and ease of use.

Roller Cabinet



Mac Tools 6-Drawer Roller Cabinet

- **Description:** A heavy-duty roller cabinet designed for maximum storage and organization.
- **Features:**
 - Ball-bearing slides for smooth drawer operation
 - Lockable drawers for security
 - Durable powder-coated finish
- **Benefits:** Keeps tools organized and easily accessible, enhancing workflow in the workshop.

Mac Tools 8-Drawer Tool Chest

- **Description:** A spacious tool chest that complements the roller cabinet for additional storage.
- **Features:**
 - Extra-wide drawers for larger tools
 - Integrated power strip for charging devices
- **Benefits:** Provides ample storage space while keeping tools organized and secure.

Double Technician Work Bench



Mac Tools Heavy-Duty Double Technician Work Bench

- **Description:** A robust workbench designed to accommodate two technicians working simultaneously.
- **Features:**
 - Sturdy steel frame with a large work surface
 - Built-in tool storage and shelving
- **Benefits:** Increases productivity by allowing multiple technicians to work on different tasks at the same time.



Mac Tools Adjustable Height Work Bench

- **Description:** A versatile workbench with adjustable height settings for ergonomic use.
- **Features:**
 - Easy height adjustment mechanism
 - Durable laminate surface for easy cleaning
- **Benefits:** Provides flexibility for technicians of different heights and preferences, promoting comfort during work.

Diagnostic Tools

Mac Tools Digital Multimeter

- **Description:** A reliable digital multimeter for diagnosing electrical issues in vehicles.
- **Features:**
 - Auto-ranging capability for ease of use
 - Backlit display for visibility in low-light conditions
- **Benefits:** Essential for troubleshooting electrical systems, ensuring accurate diagnostics.



Mac=Tools Scan Tool

- **Description:** An advanced scan tool for reading and clearing diagnostic trouble codes (DTCs).
- **Features:**
 - Compatibility with a wide range of vehicles
 - Live data streaming for real-time diagnostics
- **Benefits:** Streamlines the diagnostic process, allowing technicians to quickly identify and resolve issues.



Heavy-Duty Double Scissor Lift

- **Capacity:** 10,000 lbs
- **Lift Height:** 72 inches
- **Platform Size:** 48 x 96 inches
- **Power Source:** Hydraulic
- **Features:**
 - Robust steel construction
 - Non-slip platform surface
 - Adjustable height settings



Road Force Elite Alignment System

- **Description:** The alignment system provides precise measurements and adjustments to ensure optimal vehicle performance and tire longevity.
- **Key Features:**
 - 3D imaging technology for accurate readings
 - Real-time data analysis for immediate feedback
 - Comprehensive vehicle database for easy reference
 - User-friendly software interface



Hawke Eye Elite Laser Alignment System

- **Description:** The Hawke Eye Elite Laser Alignment System is engineered for precise alignment of rotating machinery. It utilizes advanced laser technology to ensure accurate measurements and alignment.
- **Key Features:**
 - High-precision laser technology
 - User-friendly interface
 - Durable construction for industrial use
- **Applications:** Ideal for aligning motors, pumps, and other rotating equipment in manufacturing and maintenance environments.

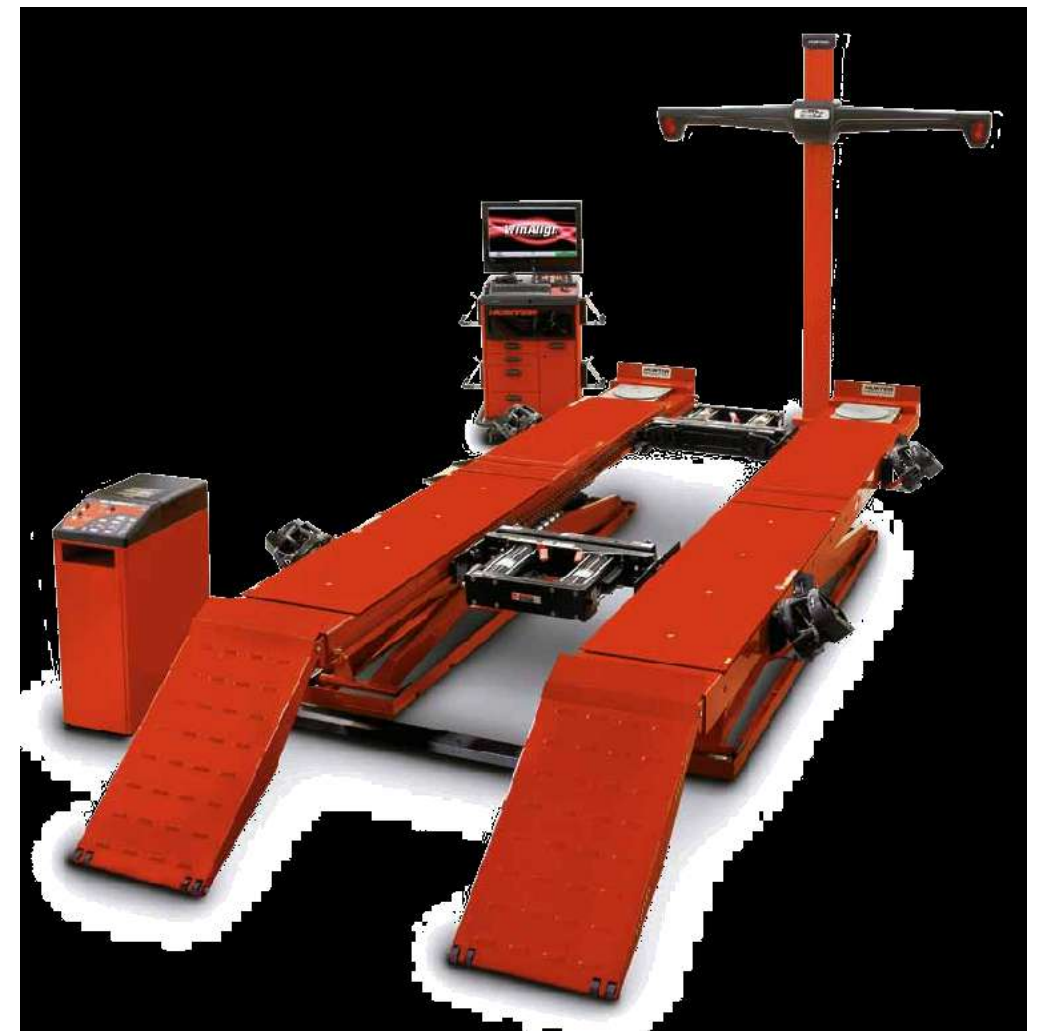

35000 Series Tyre Changer

- **Description:** The HPA 4000 is our flagship model, designed for the most demanding environments. It offers unparalleled performance and versatility.
- **Key Features:**
 - Smart technology for automatic adjustments
 - Heavy-duty construction for long-lasting use
 - Advanced safety features
- **Specifications:**
 - Power: 4 HP
 - Max Wheel Diameter: 34 inches
 - Weight: 300 kg



Accessories and Add-ons

- **Bead Seater:** For quick and efficient tyre inflation.
- **Wheel Balancer:** To ensure a smooth ride by balancing the wheels after changing.
- **Tyre Repair Kit:** Essential tools for quick repairs on the go.

Installation and Support

- **Professional Installation:** Our certified technicians ensure seamless setup and calibration.
- **Maintenance Packages:** Regular servicing to keep your system running smoothly.
- **24/7 Customer Support:** Reach us anytime for technical assistance or queries.

Contact Us

Main Headquarters:

No 8, Jalan Sepadu 25/123A, Taman Perindustrian Axis, Seksyen 25, 40400 Shah Alam, Selangor D.E., Malaysia. 📞 Direct Line: +603 5885 8500 📠 Fax: +603 2034 9538

📱 Cell Phone: +601159583672 ✉ Email: sales2@perfectlives.com 🌐 Website: www.perfectlives.com.my

PerfectLives Sdn Bhd